

robuGRIP finger gripper

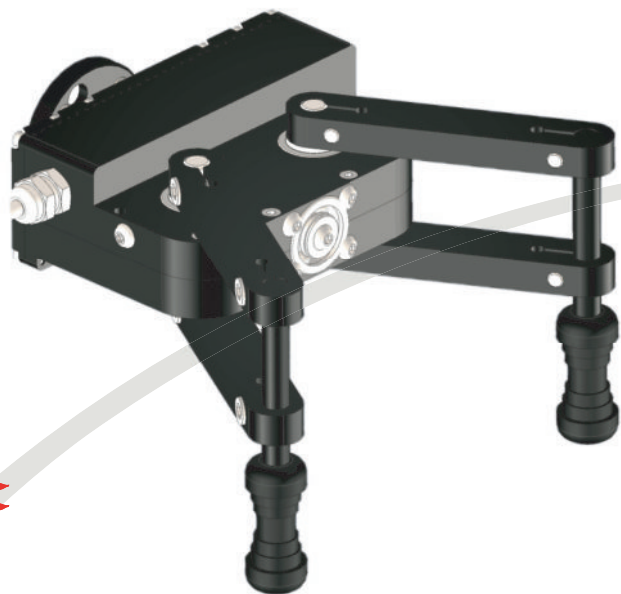

RobuGRIP is a strong two fingers gripper designed for a wide variety of grasping tasks. It features electronic torque limitation, wide opening, high payload and can be customized with various types of jaws.

General specifications :

- Type : 2 fingers angular tightening
- Jaws : polyurethane
- Finger motion : angular motion with irreversible positive tightening
- Opening : 0 to 180° in 1.5 second
- Tightening force : 100 N with 100 mm fingers
- Payload : 10 kg
- Power supply : 24 VDC
- Weight : 1.6 kg

Options :

- Angular measurement
- Custom jaws
- Tactile sensors

